



Standard Equipment/Optional Equipment

Standard Equipment

Hydrostatic power steering
 Linde twin accelerator pedals for all vehicle movements
 Central lever (joystick control) integrated into the adjustable armrest
 2 x 12 kW maintenance free AC drive motors
 25 kW AC maintenance free lift motor
 Different ECO modes providing the perfect combination of performance and efficiency
 Graphic display of battery operating time in minutes
 Automatic parking brake
 Linde dual motor drive
 Proportional reduction of travel speed when cornering (Linde Drive Assistant)
 Seamless electronic control of all traction and hydraulic movements

Standard chassis suitable for working in ISO containers with appropriate mast
 Hydraulically cushioned full suspension PVC operator's seat with armrest
 Comprehensive digital instrument display
 Generous storage facilities for writing materials and miscellaneous items
 Superelastic tyres

Mast

Clearview standard mast 3,100 mm lift
 Fork carriage width 1,350 mm for all models
 Fork length 1,000 mm

Optional Equipment

Single pedal accelerator with forward/reverse selector in the armrest
 Heating (with pollen protection filter)
 Radio with CD player
 Fabric covered comfort seat
 Super-comfort seat with air suspension, heater and backrest extension
 Super Deluxe Active Seat with full automatic weight adjustment, heating and cooling
 Swivelling seat
 Individual or single hydraulic control joystick
 Overhead guard sun blinds (front + top)
 Clipboard with LED illumination
 Front and rear screens, wipers and tops screen
 Full cab with hinged doors
 Polycarbonate top screen on overhead guard
 Tilt cylinder protection
 Alternative fork lengths
 Alternative fork carriage widths
 Integrated sideshift

One, two or three additional hydraulic circuits for attachments
 Load backrest
 Working lamps with LED technology
 Truck lighting with LED technology on rear side
 Full road lighting
 Flashing beacon/rotating beacon
 Audible reversing alarm
 Electrical socket 12 V
 External, internal and panoramic mirror
 Integrated charger unit, optionally with electrolyte circulation
 Active ventilation for battery charging
 Alternative tyre types
 Cold store protection
 Alternative custom paintwork
 Linde Fleet Management (LFM)

Other options available on request



Safety

The protective overhead guard forms a strong and completely enclosed protective zone providing optimum structural integrity, safety and protection for the operator. The top mounted tilt cylinders provide seamless, smooth control of the tilt movements for excellent load stability in all operating conditions. This unique design also enables slimmer mast profiles to be fitted for outstanding visibility.

Performance

One would expect a high performance truck to have a high performance traction system – and that is exactly what the Linde compact drive axle and lift system delivers. Powerful motors and intelligent electronic control form an impressive power pack to deliver the highest level of productivity.

Comfort

Consistently high levels of performance and efficiency for extended periods are only possible if the operator feels comfortable. The ergonomic layout of all the controls, the adjustability of the armrest and seat, Linde Load Control, and twin accelerator pedals provide the best possible intuitive interface between the truck and the operator.



Reliability

An electric forklift truck depends on reliable electronic systems. The Linde electronic control system provides a high level of reliability because of its dual circuit monitoring system and the sealed aluminium housing which provides total protection for the electronics from the ingress of dust and moisture.

Productivity

Effective in operation, efficient in reducing costs: The unique Linde energy management system ensures intelligent and economical consumption of energy. Energy can also be obtained quickly utilising the optional built-in charging unit or one of the four simple and rapid battery changing methods. The result: more uptime and increased productivity.

Features

Linde compact drive axle

- Twin drive design with high performance Linde AC technology
- Optimum energy efficiency
- Maintenance-free oil-bath vane brake
- Automatic parking brake
- Electronic components housed in sealed unit for complete protection



Linde hydrostatic power steering

- Minimal physical demands on the operator
- Compact ergonomically designed steering wheel
- Linde oscillating axle for outstanding manoeuvrability

Linde twin accelerator control

- Seamless, rapid reversing without repositioning the feet
- Short pedal travel
- Fatigue-free working
- Increased throughput and performance

Linde Load Control

- Small tactile joystick integrated in an adjustable armrest
- Precise and effortless fingertip joystick control of all mast functions
- Safe and highly efficient load handling

Linde Dual Motor Drive

- Two powerful AC drive motors integrated in the front axle
- Seamless acceleration and variable torque characteristics
- Extremely quiet in operation



Linde operator's compartment

- Ergonomic design for efficient, fatigue-free working
- Spacious operator's compartment with generous floor plate area
- Cushioned comfort – mast and drive axle are isolated from the chassis and cab by a unique resilient suspension system that absorbs shocks, vibrations and noise



Linde clearview mast design

- with top mounted tilt cylinders for seamless load control and stability
- Excellent view of load and surroundings through the robust yet slim mast profiles
- Nominal capacity retained to maximum lift heights
- High residual capacities in all applications



Linde energy management

- Optimised energy consumption
- Accurate battery condition indicator
- Simple horizontal or vertical battery changing options
- Optional built-in high frequency charger for convenience and flexibility
- Record of battery usage

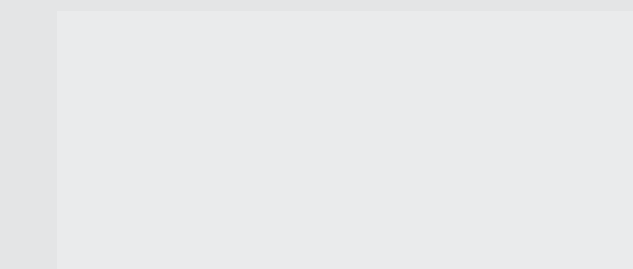

Technical Data according to VDI 2198

Characteristics	LINDE													
	E35/600H	E40/600H	E45/600H	E40/600HL	E45/600HL	E50/500HL	E50/600HL	E40/600L-Container	E45/600L-Container	E50/500L-Container	E50/600L-Container			
1.1 Manufacturer	LINDE													
1.2 Model designation	E35/600H E40/600H E45/600H E40/600HL E45/600HL E50/500HL E50/600HL E40/600L-Container E45/600L-Container E50/500L-Container E50/600L-Container													
1.3 Power unit	Battery													
1.4 Operation	Seat													
1.5 Load capacity	Q (t)													
1.6 Load centre	c (mm)													
1.8 Axle centre to fork face	x (mm)													
1.9 Wheelbase	y (mm)													
2.1 Service weight	(kg)													
2.2 Axle load with load, front/rear	(kg)													
2.3 Axle load without load, front/rear	(kg)													
3.1 Tyres rubber, SE, pneumatic, polyurethane	SE													
3.2 Tyre size, front	355/45-15 (28x12.5-15)													
3.3 Tyre size, rear	225/75-10 (23x9-10)													
3.5 Wheels, number front/rear (x = driven)	2x / 2													
3.6 Track width, front	b10 (mm)													
3.7 Track width, rear	b11 (mm)													
4.1 Mast/fork carriage tilt, forward/backward	a/b (°)													
4.2 Height of mast, lowered	h1 (mm)													
4.3 Free lift	h2 (mm)													
4.4 Lift	h3 (mm)													
4.5 Height of mast, extended	h4 (mm)													
4.7 Height of overhead guard (cabin)	h6 (mm)													
4.8 Height of seat/stand-on platform	h7 (mm)													
4.12 Towing coupling height	h10 (mm)													
4.19 Overall length	l1 (mm)													
4.20 Length to fork face	l2 (mm)													
4.21 Overall width	b1/b2 (mm)													
4.22 Fork dimensions	s/e/l (mm)													
4.23 Fork carriage to ISO 2328, class/type A, B	3A													
4.24 Width of fork carriage	b3 (mm)													
4.31 Ground clearance, below mast	m1 (mm)													
4.32 Ground clearance, centre of wheelbase	m2 (mm)													
4.33 Aisle width with pallet 1000 x 1200 across forks	Ast (mm)													
4.34 Aisle width with pallet 800 x 1200 along forks	Ast (mm)													
4.35 Turning radius	Wa (mm)													
4.36 Minimum pivoting point distance	b13 (mm)													
5.1 Travel speed, with/without load	(km/h)													
5.2 Lifting speed, with/without load	(m/s)													
5.3 Lowering speed, with/without load	(m/s)													
5.5 Tractive force, with/without load	(N)													
5.6 Maximum tractive force, with/without load	(N)													
5.7 Climbing ability, with/without load	(%)													
5.8 Maximum climbing ability, with/without load	(%)													
5.9 Acceleration time, with/without load	(s)													
5.10 Service brake	hydr./mech.													
6.1 Drive motor, 60 minute rating	(kW)													
6.2 Lift motor rating at S3 15%	(kW)													
6.3 Battery according to DIN 43531/35/36 A,B,C,no	43 536 / A													
6.4 Battery voltage/rated capacity (5h)	(V/Ah)													
6.5 Battery weight (± 5%)	(kg)													
6.6 Power consumption according to VDI cycle	(kWh/h)													
8.1 Type of drive control	Digital/stepless													
8.2 Operating pressure for attachments	(bar)													
8.3 Oil flow for attachments	(l/min)													
8.4 Noise level at operator's ear	(dB(A))													

1) Figures with battery, see line 6.4/6.5.

2) Including a 200 mm (min.) operating aisle clearance.

Load Capacity Diagrams

Valid for Standard mast and fork carriage with SE tyres 28x12.5-15

E 35/600 H

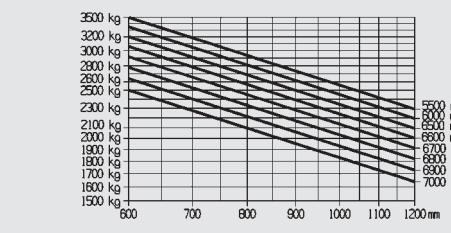

E 40/600 H, E 40/600 HL

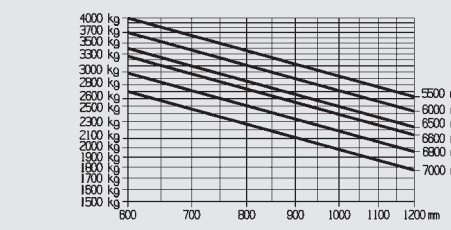

E 45/600 H, E 45/600 HL

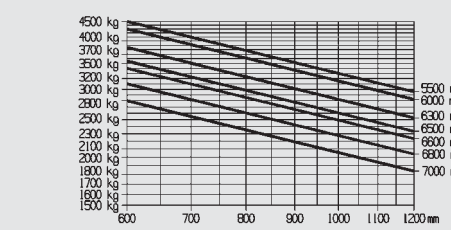

E 50/500 HL

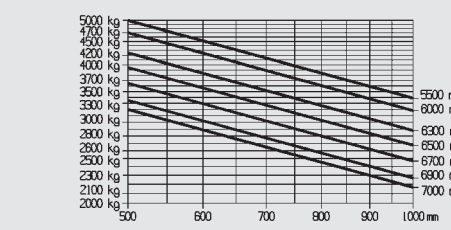

E 50/600 HL

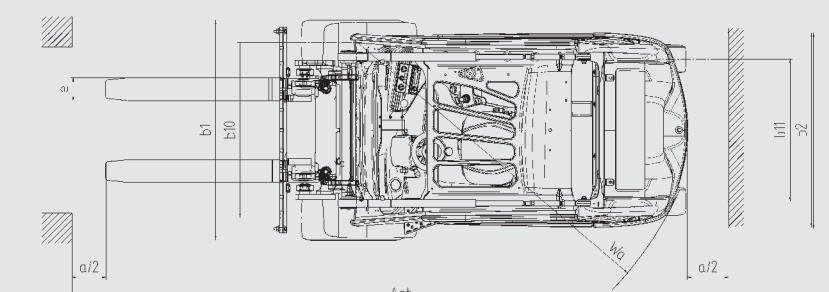
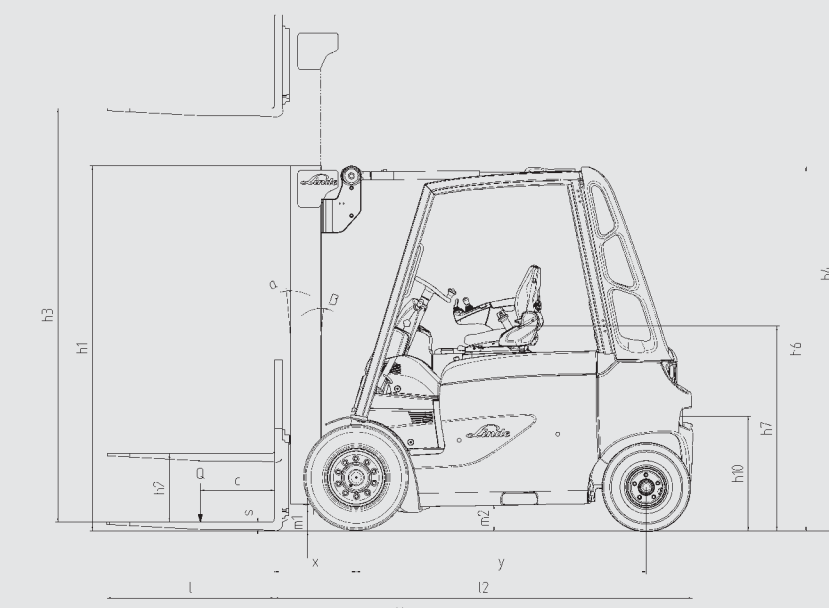
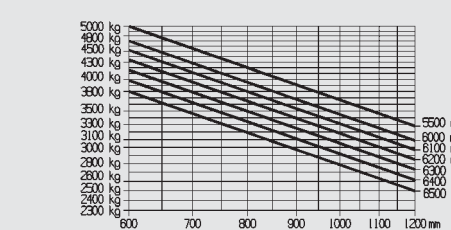

Standard mast	E35/600H E40/600H; E40/600HL E45/600H; E45/600HL E50/500HL					E50/600HL				
	h3	h1	h2	h3	h4	h3	h1	h2	h3	h4
Lift	3100	3700	4100	4400	5000	3200	3700	4100	4400	5000
Mast retracted	2404	2704	2904	3054	3354	2554	2804	3001	3154	3454
Mast extended	4000	4600	5000	5300	5900	-	-	-	-	-
Free lift	150	150	150	150	150	150	150	150	150	150

Triplex mast	E35/600H E40/600H; E40/600HL E45/600H; E45/600HL E50/500HL			E50/600HL			E40/600L E45/600L Cont.	E50/500L E50/600L Cont.
	h3	h1	h2	h3	h1	h2	h3	h1
Lift	4675	5515	6015	4375	4615	5065	5565	3925
Mast retracted	2360	2660	2860	2360	2660	2860	2210	2210
Mast extended	5575	6415	6915	5575	6415	6915	5125	4924
Free lift	1460	1760	1960	1460	1760	1960	1310	1210

Figures in mm
Figures for other masts on request